



ANALOG WAY®

QUICK START GUIDE

Di-VentiX II - Ref. DVX8044

Thank you for choosing **Analog Way** and the **Di-VentiX II**. By following these simple steps, you will be able to setup and use your powerful Multi-Layer, Hi-Resolution Mixer, Scaler, Seamless Switcher within minutes. Discover the **Di-VentiX II** extensive capabilities and intuitive interface while configuring your first show, and unleash your creativity for a new experience in show and event management by **Analog Way**.

What's in the box

- 1 x Di-VentiX II (DVX8044)
- 1 x Power supply cord.
- 1 x MCO 8 pin Connector
- 1 x Optional Audio board (OPT-8044-A)
- 1 x Optional Video Output (OPT-8044-VO) + Video Output Cable DB9

- 1 x RCS (Remote Control Software for PC only) *
- 1 x User Manual (PDF version) *
- 1 x Quick Start Guide (PDF version)*

* *Download on our website: www.analogway.com*

Quick install and setup

Getting started:

You may wish to reset the unit to factory settings to get started. Go to: **Menu --> Control --> Default Values --> Yes**.

1. Select the Output resolution that matches the native resolution of your display. You will next be prompted to choose enable follow mode if desired and output rate.

Menu --> Output --> Output format --> 1024x768 --> Internal Ref --> 60 Hz.

2. Inputs can be configured automatically using the *Auto Set All* function.

Menu --> Inputs --> AutoSet All.

It will scan each input and detect the sync type that is plugged in. You can still do an *Autoset* or manual setup per input.

The Di-VentiX II has 8 layers available called: **[BACKGROUND FRAME]**, **[A]**, **[B]**, **[C]**, **[D]**, **[LOGO1]**, **[LOGO2]** and **[MASK FRAME]**. Each layer will obscure your view other layers below.

3. To display a source **[A]**, **[B]**, **[C]**, **[D]**, select the **[A]** layer (it will begin to blink) then, select a source (it will also blink). Press **[TAKE]** to transition your source from preview to program output.

There will always be a layer selected (blinking) and a source selected (blinking) to the selected layer (blinking). To view on preview or change the contents of a different layer, simply select it.

4. To display a PIP, select another layer **[B]**, **[C]** or **[D]** (it will begin to blink) then select your source (it will also blink). Press **[TAKE]** to display the PIP on program output.

To see the layer beneath, you will need to clear or move the layers that are on top.

5. To clear the PIP or any other layer, select the layer (it will blink) then, select **[BLACK]**. Press **[TAKE]** to remove the layer from the program output.

TIP If you would like the Program and Preview to toggle/flipflop during each Take, enable this feature by going to **Menu --> Control --> Preset Toggle**.

Once enabled, everything on the Program output will become the Preview during each Take.

6. To display a logo or frame (framestore) follow the steps on page 4.

See the next page which describes the button lighting color code and other front panel features.

Di-VentiX II can be used to display (in Mixer and SEB Mode):

- sources seamlessly switched in the **Background Live layer**.
- **3 PIPs** and 2 Logos over the Background Live layer.
- **4 PIPs** and 2 Logos over a Background Frame by resizing the Background Live layer.

IMPORTANT: Simply selecting a menu item will not set it to that value. Be sure to press the **ENTER** button when parametering the menu items.

Di-VentiX II - Ref. DVX8044

Front Panel Description

INPUT / FRAME SELECTION

#1 to #8: Press to access analog source #1 to #8
BLACK: Clear the active layer
FREEZE: Freeze the input linked to the current layer on MAIN

ADJUST

1:1: Press to adjust the aspect out 1:1 for the image
Full Screen: to adjust the image to full screen
Cropped: to adjust the image to cropped

LAYERS

Press to select a layer, then choose an input.
LOGO: Display a partial screen Logo
Mask Frame: display a Mask Frame
Bkgn Frame: Display full screen frame in this layer

LAYER HIERARCHY

- Mask Frame
- Logo 2
- Logo 1
- Layer D
- Layer C
- Layer B
- Layer A
- Background Frame

CONTROL

EXIT/MENU: Home Menu or back one level
ENTER: Validates the menu or command

STEP BACK

Recall the last preset into your preview monitor

TAKE

Transition the pre-selected sources onto the MAIN output with the selected effects

PRESET

Recall a custom stored preset (4 memories available).
 To store a preset, use Menu -> Preset.

BUTTON COLOR USAGE

Solid red:		#1 = Source is on the main outputs #2 = Freeze enable #3 = Stand-by button #4 = Preset Selection
Solid green:		#1 = Source is on Preview #2 = Function available for modification
Blinking red:		Layer/source selected, and is currently active on the main output
Blinking green:		Layer/source selected, and is not currently active on the main output

OPERATIONS OVERVIEW

WORKING IN MIXER MODE

- 1- Select a Layer then select an **INPUT**.
- 2- On the preview screen, the input appears
- 3- Select an **[EFFECT]** (open/close)
- 4- Press **[TAKE]** to view the result on the Main screen
- 5- Try enabling the 'Preset Toggle' from the Control menu to have your preview replaced by program during each Take

WORKING WITH PIPs IN MIXER MODE

- 1- Press one of the layers button. On the preview screen, the PIP (layer) appears as a color rectangle
- 2- Select an input. On the preview screen, the input appears in the layer rectangle
- 3- Adjust the PIP (layer) with **Layer menu** (Pos & Size or Zoom by Toggle function)
- 4- Select a transition (open/close) or an effect into Layer menu **HOME MENU**
- 5- Press **[TAKE]** to view the result on the main screen
- 6- To remove layer, press **[BLACK]** then **[TAKE]**
- 7- For another PIP setup, repeat from step #1

INPUT SETUP

- 1- Press the **[EXIT/MENU]** button from the Home menu (all functions must be confirmed by the **[ENTER]** button)
- 2- Select **INPUT** and **AUTOSSET ALL**
- 3- If the acquisition has failed, check all connections and perform a manual setup
- 4- For a comprehensive Input Setup, please refer to user's Manual
- 5- For a manual input setup, press the **[EXIT/MENU]** button:
 - a) Select **INPUT**,
 - b) Select an input from Input #1 up to SDI #2, then
 - c) Select **TYPE**.

NOTE: To adjust input Size or Pos, use the Layer Menus. To adjust Blanking, use the Auto-Centering or Blanking adjustments in the Image menu.

OUTPUT SETUP

- 1- Press the **[EXIT/MENU]** button from the Home menu (all functions must be confirmed by the **[ENTER]** button)
- 2- Select **OUTPUT**
- 3- Select **OUTPUT FORMAT**
- 4- On Format line, select the display's native resolution
- 5- Control or adjust your display device (Monitor or Video Projector)
- 6- If necessary, select **TEST PATTERN** in the Output menu

Di-VentiX II - Ref. DVX8044

Rear Panel Description

WORKING WITH DVX8044

The features of DVX8044 can be controlled by the external remote control as:

- Orchestra - Ref. ORC50
- Axion2 - Ref. ARC200
- Remote Control Software - Ref. RCS (supplied)
- Remote Keypad with T-Bar - Ref. RKD8044

RS-232 communication port on a DB9 female connector

IP-LAN connector

GP-I/O connector

Power supply: IEC/EN/UL/CSA 60950-1, internal, autoswitchable

Genlock in/out connectors

Optional audio in/out card (OPT-8044A)

Optional video out card (OPT-VO-8044)

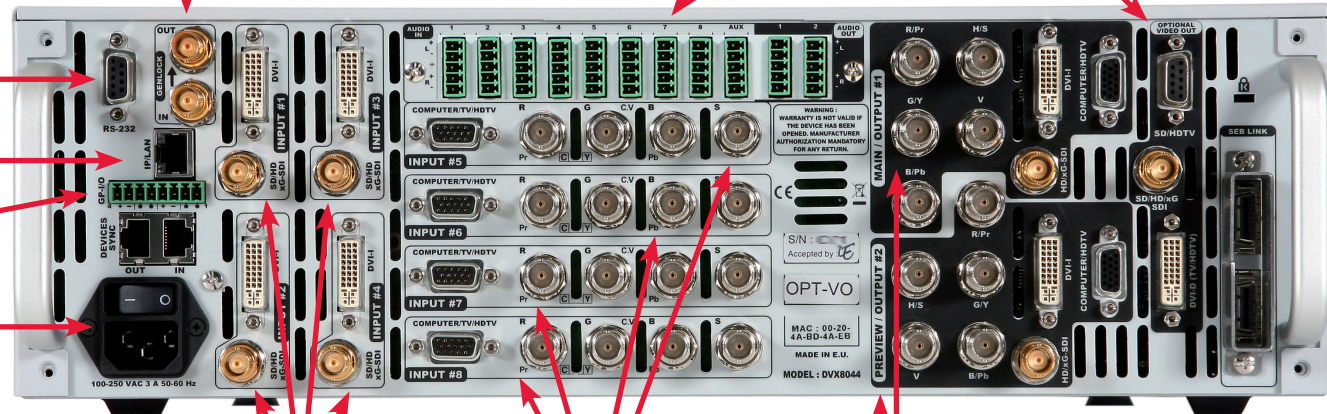

Universal Digital and Analog inputs #1 to #4

Universal Analog Computer TV/HDTV inputs #5 to #8

Outputs #1 (Main) & #2 (Preview): female HD15, DVI-I (simultaneous analog and digital outputs), SDI, 5 BNC depending on the output format

HOW TO ADJUST A SOURCE?

HOME MENU (extract)

IMAGE (A3)

(A3) displayed when an input is active

- Auto Centering^(R1)
- Blanking Adjust^(R2)
 - H position
 - V position
 - H size
 - V size...
 - H start
 - H End
 - V start
 - V Ene...
- Input zoom
 - H Total
- Optimize^(R1)
 - Phase
- Under/Over^(R3)
 - Underscan
 - Overscan
- Aspect IN
 - Native
 - LetterBox_1_78
 - LetterBox_2_35
 - Anamorphic
 - Pillar Box
- Aspect OUT
 - 1_1
 - Centered
 - Full screen
 - Cropped
- Force 4:3^(R9)
- Colorimetry
 - Brightness
 - Contrast
 - Color^(R5)
 - Hue^(R6)
 - Component Level^(R2)
 - Red Level^(R6)
 - Green Level^(R6)
 - Blue Level^(R6)
- Advanced^(R2)
 - 2:2 Pulldown^(R7)
 - 3:2 Pulldown^(R8)
 - Reset Default

* Motion Correction

The Menu allows to improve the threshold of the comb filter.

0% means no adjustments and 100% is the max. The setting is manual with a visual correction.

The result is the removal of the aliasing in the moving picture.

HOME MENU

The Home Menu is the system's top level menu, from which all others menus can be accessed. To access a menu, press the [MENU] button. To navigate in the Home Menu, please use the knob. To confirm, please use the [ENTER] button. You can also return to the Home Menu by pressing the [EXIT] button.

- **INPUT:** configure the 10 individual input types and resolutions
- **OUTPUT:** configure the 2 outputs in terms of resolution and rates
- **VIDEO OUT:** configure the video optional output (format, rate, patterns)
- **PRESET:** store and use presets
- **IMAGE:** change source image settings of an input
- **LAYER:** adjust Layer size, position, border transparency or Transition
- **KEYING/TITLING:** access keying and titling controls and parameters for the selected layer
- **LOGOS/FRAMES:** store (record), and manage layers and frames. To display a frame or logo, use the frame or logo layer (see next page)
- **AUDIO:** access all audio input and output parameters
- **SOFTEDGE:** access to softedge adjustments, only in Softedge Mode
- **CONTROL:** access device software information, LAN settings, reset factory settings, amongst other user oriented functions (see next page)

AUDIO INPUT/OUTPUT CONNECTIONS (Optional audio board)

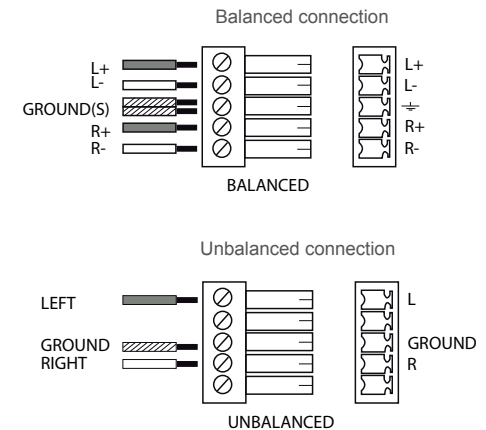

How to do an AutoTake?



The Autotake function performs a TAKE automatically each time an input is selected or a change is done (position/size).

How to record & display a still Frame?



The [Empty] term appears next to all unused slots

Frame: Full and individual picture.

Logo: Part of picture like a graphic symbol which represent a company or organisation.

It is possible to store up to 8 frames and 8 logos (in Mixer Mode) in the DVX8044 non volatile memory (in SEB Mode, 4 frames and 8 logos).

- ▶ Select RECORD FRAMES in the Logos/Frames menu.
- ▶ A white rectangle will appear on your main display, indicating the Frame which will be captured.
- ▶ Select an empty frame memory to store the frame into. Your frame will now be stored.
- ▶ To recall a frame: press the [BKGND/FRAME] button, select a frame number (#1 to #8), then press the [TAKE] button. Your Background Frame will appear on your main screen, under any other active layers. Be sure to clear or move any other layers to expose the Background Frame layer.
- ▶ To remove the Background Frame, press [BLACK] button, then [TAKE] button.
- ▶ Once you have recall a frame, you can recall live layers on the top of it.

TIP: A long press on the [BACKGROUND FRAME] button will set all other layers to black/clear on the preview. Press

How to disable the HDCP encryption?

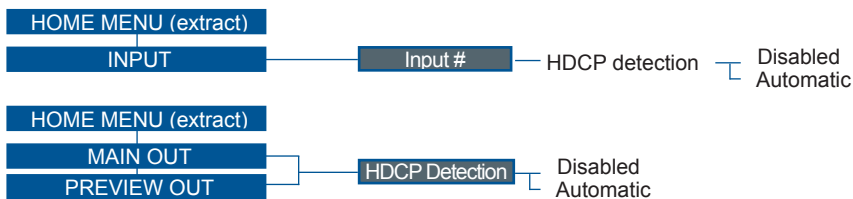

The HDCP Encryption can be disabled on DVI inputs #1 to #2 or/and Main Output / Preview Output. This can be useful when you have a computer which is detecting the HDCP compliance of your switcher and protecting the content by encrypting the signal from this computer. This feature will disable the HDCP compliance on this specific DVI input only.

If you want to use HDCP content from your sources, be sure to use only HDCP compliant screens or projector. If it's not the case, the output image could be disabled. When displaying HDCP protected sources on non HDCP compliant equipment, the following message will be displayed on the device screen: « Due to HDCP content, non HDCP screens cannot display protected sources ».

Screen will go to black without displaying the HDCP input image, or partially layer out on HDCP content.

The output status can provide you all information about the output in real time. This feature is particularly useful when HDCP is used with long cable to be sure the communication is well handled.

How to use the Auto-Lock Function?



[AUTO-LOCK] allows to select an input only if a signal is connected.

Warranty

This **Analog Way** product has a 3 year warranty on parts and labor, back to factory. This warranty does not include faults resulting from user negligence, special modifications, electrical surges, abuse (drop/crush), and/or other unusual damage.

Going further with the Di-VentiX II

For complete details and operations procedures, please refer to the **Di-VentiX II** User's Manual and our website for further information: www.analogway.com